

MT516

■ Dimensions(mm)

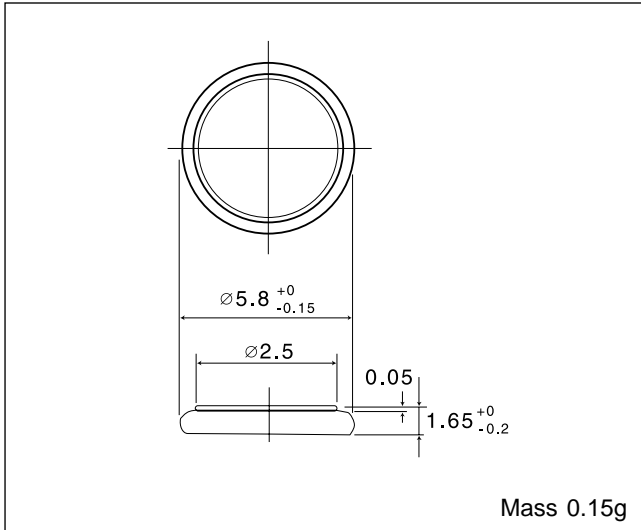

■ Specification

Nominal voltage(V)	1.5
Nominal capacity(mAh)	1.15
Continuous drain(mA)	0.05
Operating temperature(°C)	-20 ~ +60

■ Charge / discharge characteristics

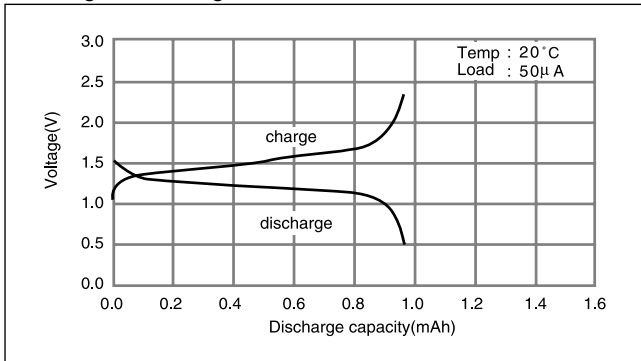

■ Consumption current vs. Duration time

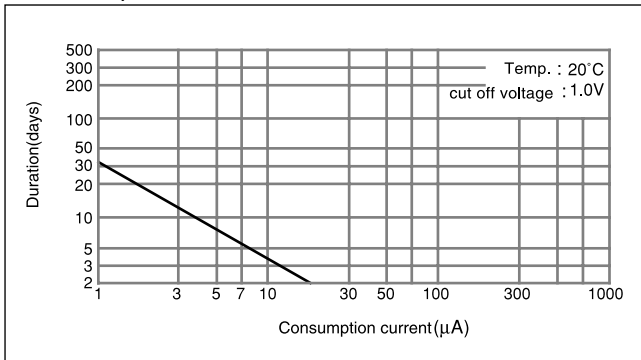

MT616

■ Dimensions(mm)

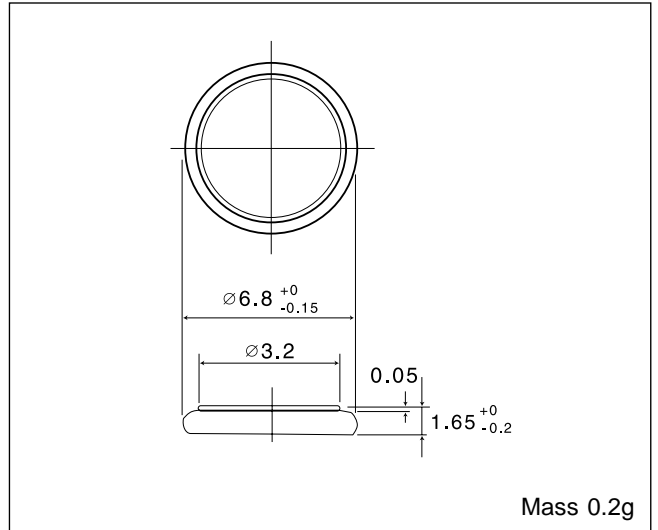

■ Specification

Nominal voltage(V)	1.5
Nominal capacity(mAh)	1.05
Continuous drain(mA)	0.05
Operating temperature(°C)	-20 ~ +60

■ Charge / discharge characteristics

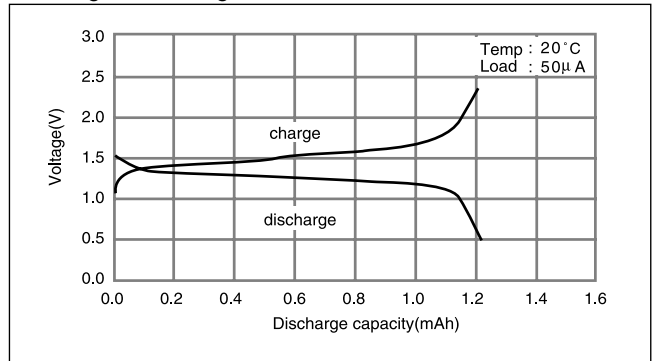

■ Consumption current vs. Duration time

