

ML621S

■ Dimensions(mm)

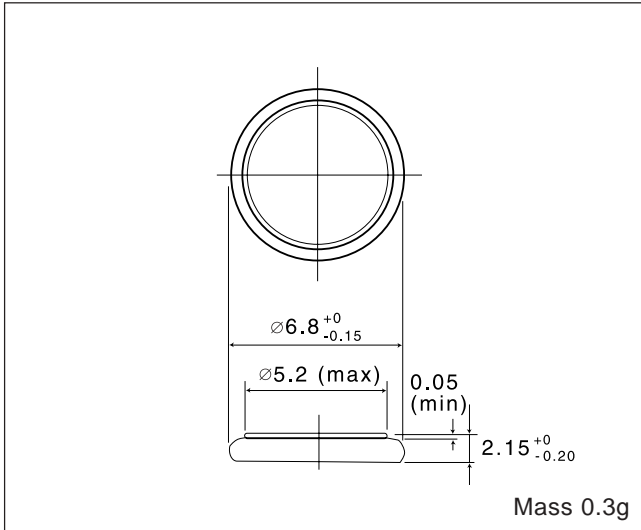

■ Specification

Nominal voltage(V)	3
Nominal capacity(mAh)	5
Continuous drain(mA)	0.01
Operating temperature(°C)	-20 ~ +60

■ Discharge characteristics

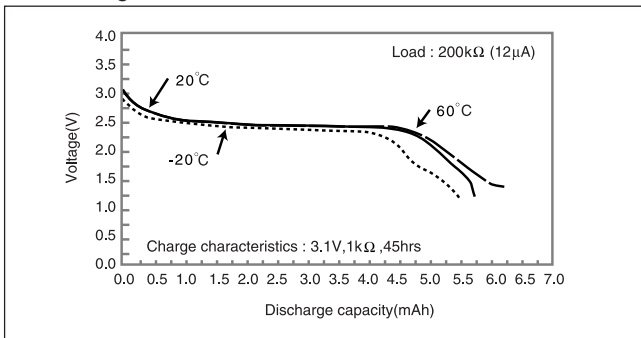

■ Charge characteristics

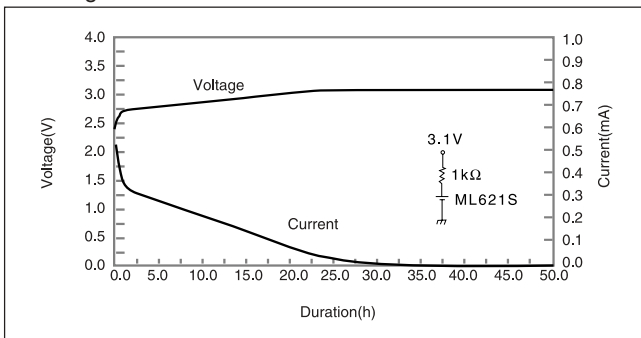

■ Consumption current vs. Duration time

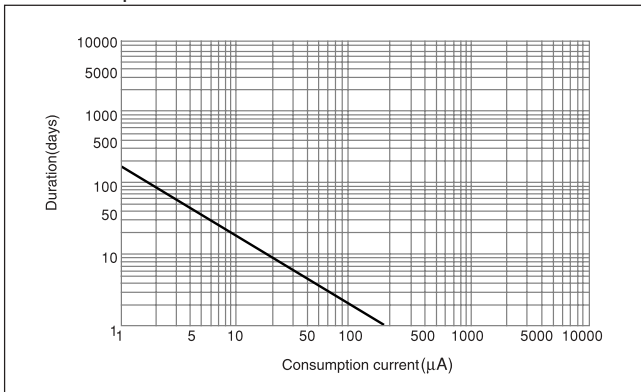

ML920S

■ Dimensions(mm)

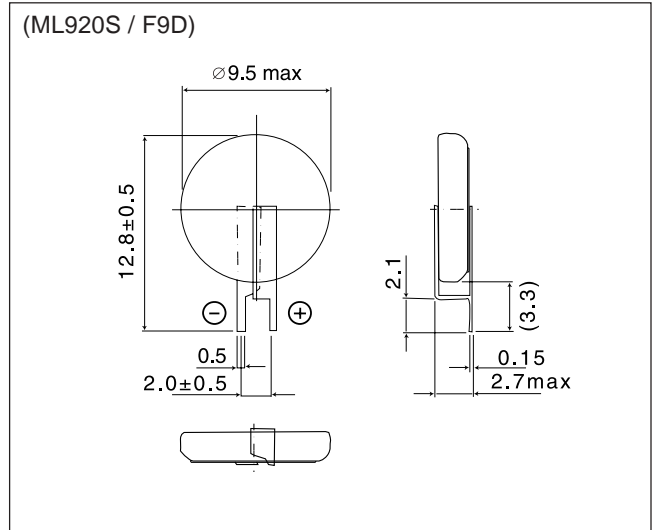

■ Specification

Nominal voltage(V)	3
Nominal capacity(mAh)	11.0
Continuous drain(mA)	0.03
Operating temperature(°C)	-20 ~ +60

■ Discharge characteristics

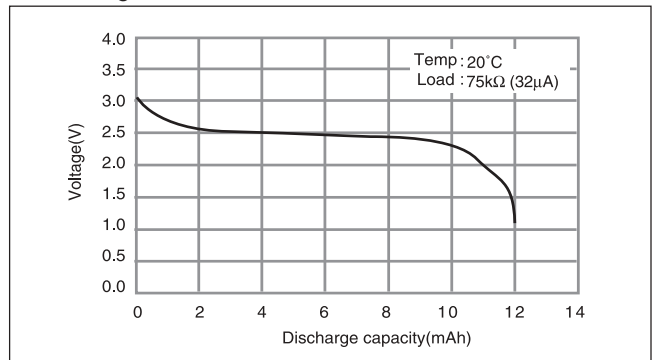

■ Consumption current vs. Duration time

