

LC-X12120P

For standby power supplies.
Expected trickle design life: 10 – 12 years at 20 °C according to Eurobat.

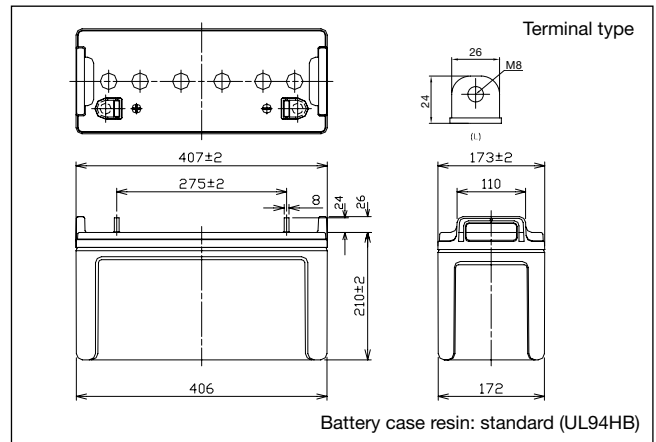

Dimensions (mm)



Specifications

Nominal voltage	12 V	
Nominal capacity (20 hour rate)	120 Ah	
Dimensions	Length	407 mm
	Width	173 mm
	Height	210 mm
	Total Height	236 mm
Approx. mass	37 kg	
Terminal	M8 Bolt and Nut type	

Duration of discharge vs Discharge current

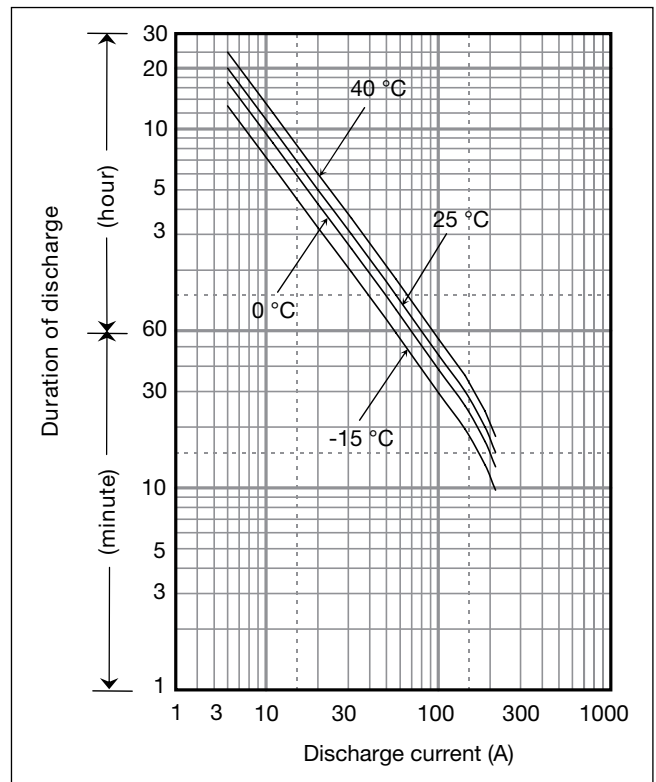

Characteristics

Capacity (25 °C)	20 hour rate	120 Ah
	10 hour rate	109 Ah
	5 hour rate	99 Ah
	1 hour rate	74 Ah
Internal resistance	Fully charged battery (25 °C)	3.5 mΩ
Temperature dependency of capacity (20 hour rate)	40 °C	102 %
	25 °C	100 %
	0 °C	85 %
	-15 °C	65 %
Self discharge (25 °C)	After 3 months	91 %
	After 6 months	82 %
	After 12 months	64 %

Watt Table

(Wattage/Battery)

Cut-off V	15min	20min	30min	45min	1h	1.5h	2h	3h	4h	5h	6h	10h	20h	24h
9.6V	1920	1677	1409	1095	835	663	499	326	261	197	179	104	60.2	46.8
9.9V	1910	1667	1370	1062	820	662	486	322	255	191	177	103	60.1	46.8
10.2V	1901	1648	1322	1040	805	642	479	315	249	185	168	101	60.0	46.7
10.5V	1796	1571	1316	1025	764	629	470	310	246	184	166	101	60.0	46.6
10.8V	1739	1532	1281	980	672	559	458	306	240	180	163	100	59.9	46.6

Ampere Table

(Ampere/Battery)

Cut-off V	15min	20min	30min	45min	1h	1.5h	2h	3h	4h	5h	6h	10h	20h	24h
9.6V	229	198	149	105	86.9	59.3	47.9	32.1	23.7	20.6	17.4	11.1	6.00	5.04
9.9V	228	197	148	102	86.6	58.1	47.5	31.5	23.4	20.4	17.4	11.1	6.00	5.04
10.2V	227	195	146	102	85.9	57.7	46.9	31.2	23.2	20.0	17.3	11.0	6.00	5.04
10.5V	215	186	143	101	85.4	56.9	46.3	31.3	23.2	20.0	17.3	11.0	6.00	5.04
10.8V	208	181	141	87	74.0	51.2	44.0	29.9	22.7	19.8	16.7	10.9	5.88	5.00

Charging Method

Trickle use Control voltage: 13.6 - 13.8 V; Initial current 18 A or smaller

Cut off voltage

Discharge current	6 A - 24 A	24 A - 60 A	60 A - 120 A	120 A - 240 A
Cut off voltage (V)	10.5	10.2	9.9	9.3

Influence of Temperature on Trickle life

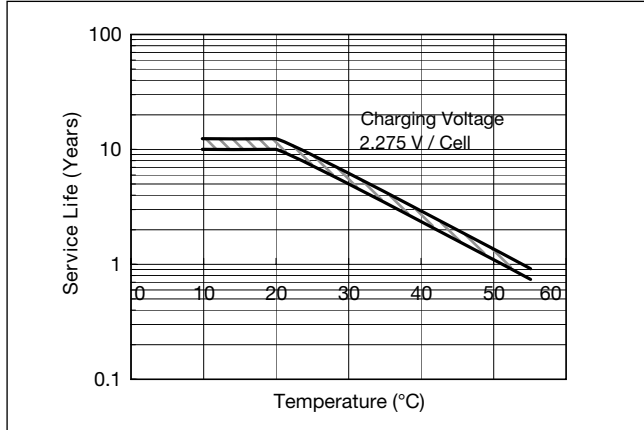

Residual capacity vs storage period

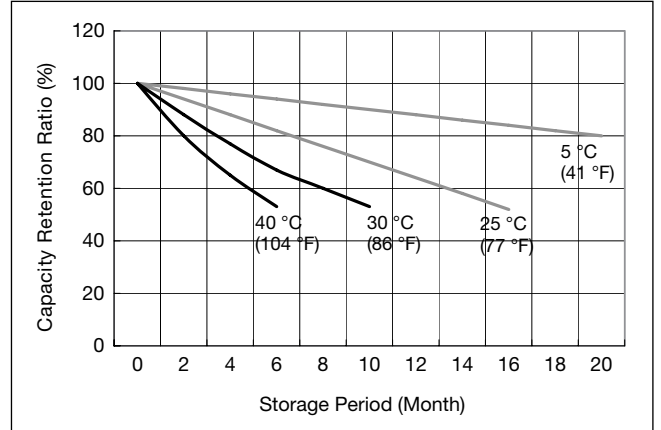

Constant-voltage and constant-current charge characteristics for Trickle use

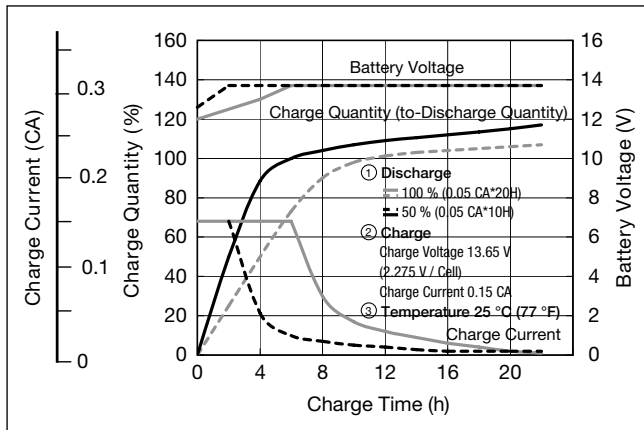

Discharge capacity by temperature and by discharge current

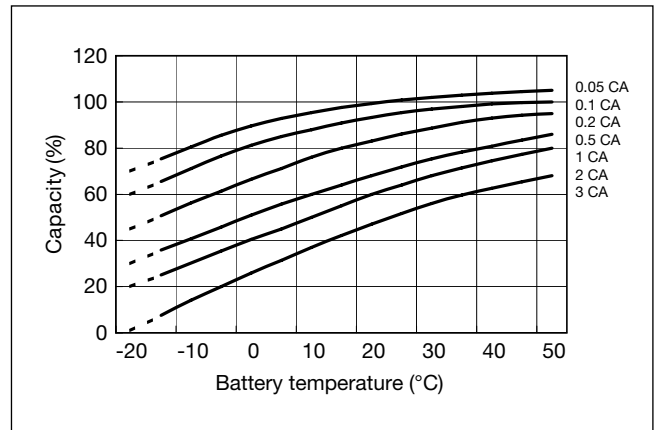

Discharge characteristics

