

LC-P067R2P

For standby power supplies.
Expected trickle design life: 10 – 12 years at 20 °C according to Eurobat.

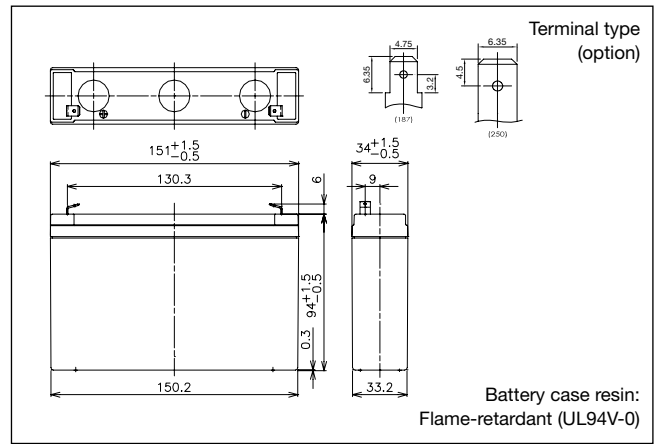

Dimensions (mm)



Specifications

Nominal voltage	6 V	
Nominal capacity (20 hour rate)	7.2 Ah	
Dimensions	Length	151 mm
	Width	34 mm
	Height	94 mm
	Total Height	100 mm
Approx. mass	1.30 kg	
Terminal	Faston 187 or Faston 250 with hole	

Characteristics

Capacity (25 °C)	20 hour rate 10 hour rate 5 hour rate 1 hour rate	7.2 Ah 6.8 Ah 6.3 Ah 4.9 Ah
Internal resistance	Fully charged battery (25 °C)	11 mΩ
Temperature dependency of capacity (20 hour rate)	40 °C	102 %
	25 °C	100 %
	0 °C	85 %
	-15 °C	65 %
Self discharge (25 °C)	After 3 months	91 %
	After 6 months	82 %
	After 12 months	64 %

Duration of discharge vs Discharge current

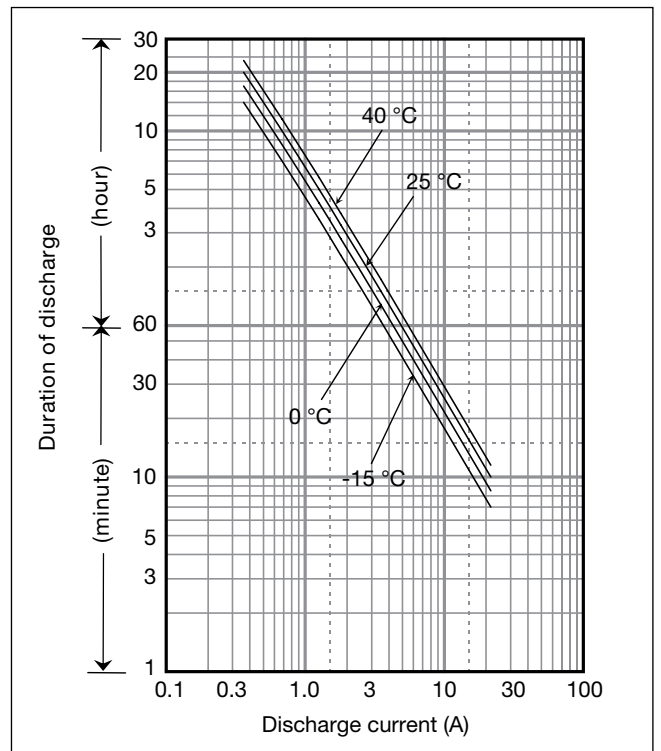

Watt Table

(Wattage/Battery)

Cut-off V	3min	5min	10min	15min	20min	30min	45min	1h	1.5h	2h	3h	4h	5h	6h	10h	20h	24h
4.8V	216	171	111	85.1	71.3	53.2	37.6	30.0	20.7	16.0	11.9	9.14	7.55	6.07	4.02	2.18	1.82
4.95V	201	160	109	84.5	70.2	52.7	37.3	30.0	20.3	15.9	11.8	9.08	7.49	6.04	4.00	2.17	1.81
5.1V	185	150	106	82.8	69.0	52.1	37.0	29.5	19.8	15.5	11.7	9.02	7.43	6.00	3.96	2.17	1.81
5.25V	165	134	99	77.1	65.5	50.9	36.4	28.9	19.4	14.9	11.5	8.96	7.37	5.92	3.94	2.16	1.80
5.4V	139	119	88	71.9	63.8	49.1	35.8	28.3	18.9	14.2	11.3	8.84	7.19	5.83	3.90	2.15	1.79

Ampere Table

(Ampere/Battery)

Cut-off V	3min	5min	10min	15min	20min	30min	45min	1h	1.5h	2h	3h	4h	5h	6h	10h	20h	24h
4.8V	38.9	30.6	19.9	14.8	12.3	9.1	6.4	5.1	3.5	2.7	2.00	1.50	1.26	1.00	0.67	0.36	0.30
4.95V	36.1	28.7	18.5	14.8	12.1	9.0	6.4	5.1	3.4	2.6	2.00	1.50	1.25	1.00	0.67	0.36	0.30
5.1V	33.3	26.9	19.0	14.4	11.9	8.9	6.3	5.0	3.3	2.5	1.95	1.50	1.24	1.00	0.66	0.36	0.30
5.25V	29.6	24.1	17.6	13.4	11.3	8.7	6.2	4.9	3.3	2.5	1.95	1.50	1.23	1.00	0.66	0.36	0.30
5.4V	25.0	21.3	15.7	12.5	11.0	8.4	6.1	4.8	3.2	2.4	1.90	1.50	1.20	1.00	0.65	0.35	0.30

Charging Method

Trickle Use	Control voltage 6.8 - 6.9 V; Initial current 1.08 A or smaller
-------------	--

Cut off voltage

Discharge current	0.36 A - 1.44 A	1.44 A - 3.6 A	3.6 A - 7.2 A	7.2 A - 14.4 A	14.4 A - 21.6 A
Cut off voltage (V)	5.25	5.1	4.95	4.65	4.35

Influence of Temperature on Trickle life

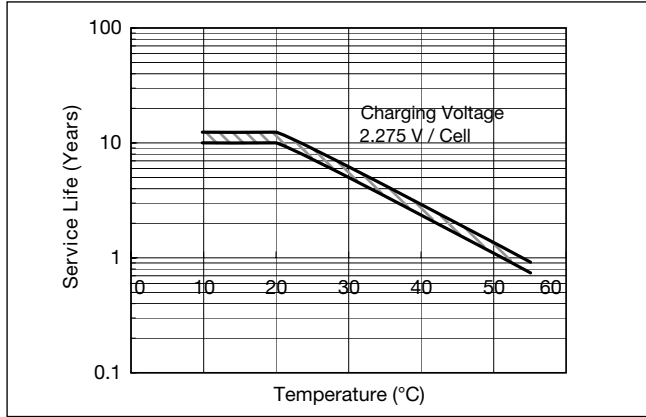

Residual capacity vs storage period

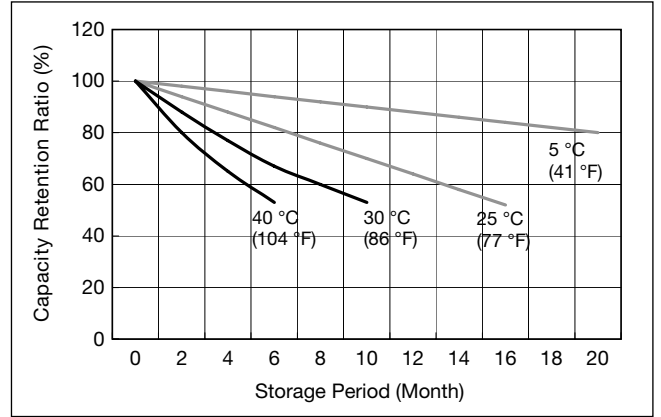

Constant-voltage and constant-current charge characteristics for Trickle use

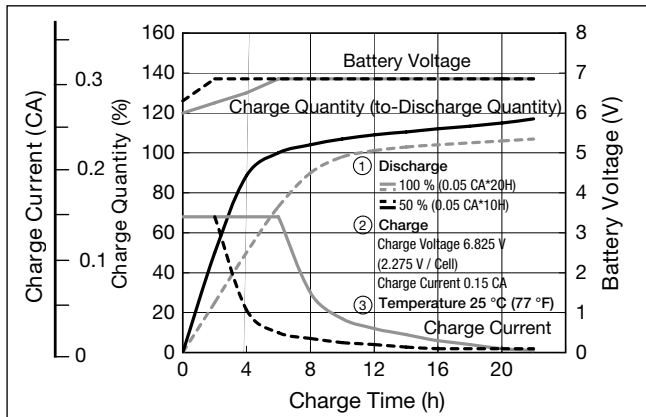

Discharge capacity by temperature and by discharge current

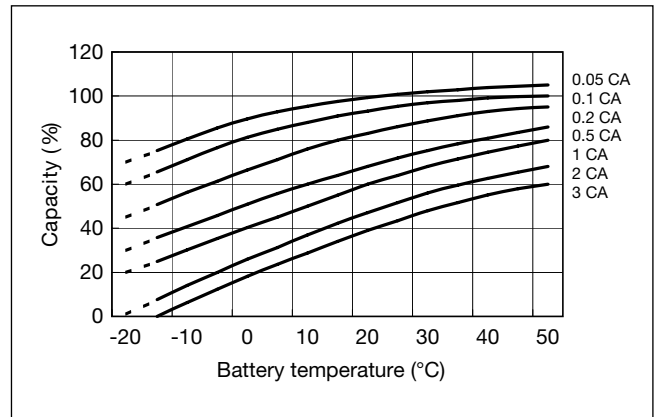

Discharge characteristics

