

# CR1216

## ■ Dimensions(mm)

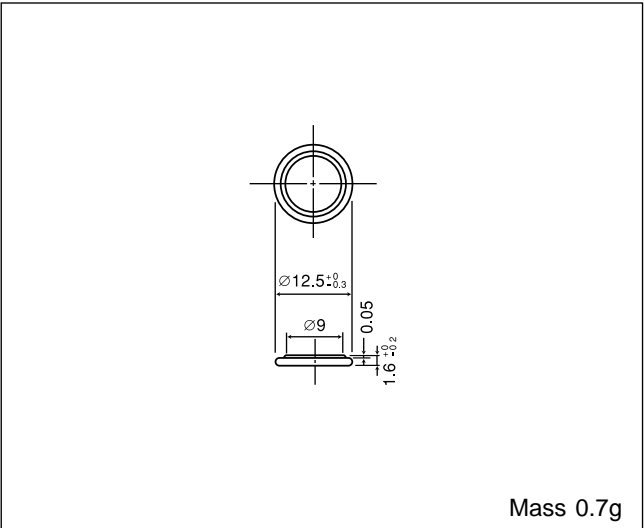

## ■ Specification

<b>Nominal voltage(V)</b>	3
<b>Nominal capacity(mAh)</b>	25
<b>Continuous drain(mA)</b>	0.1
<b>Operating temperature(°C)</b>	-30 ~ +60

## ■ Temperature Characteristics

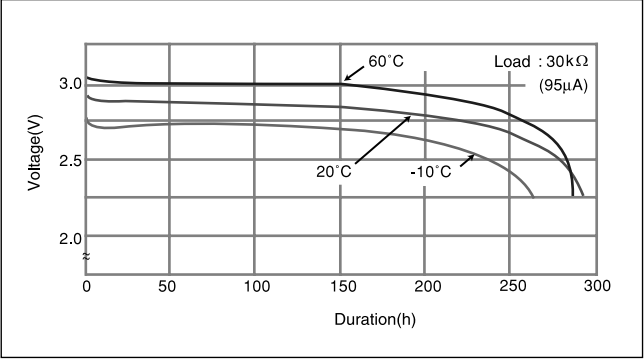

## ■ Operating voltage vs. load resistance(voltage at 50% discharge depth)

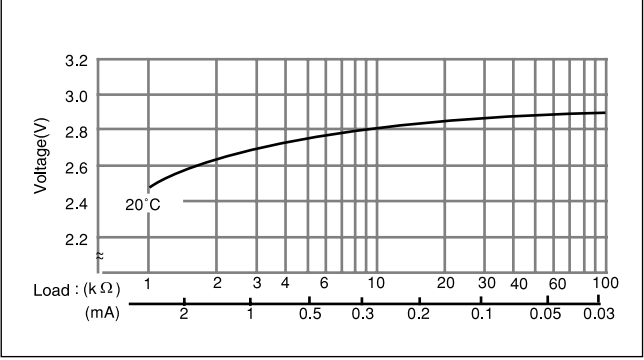

## ■ Capacity vs. load resistance

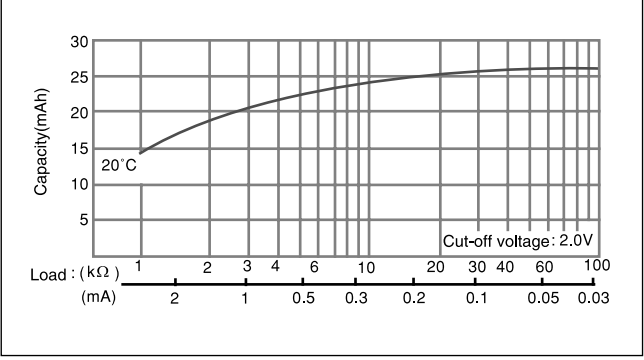

# CR1220

## ■ Dimensions(mm)

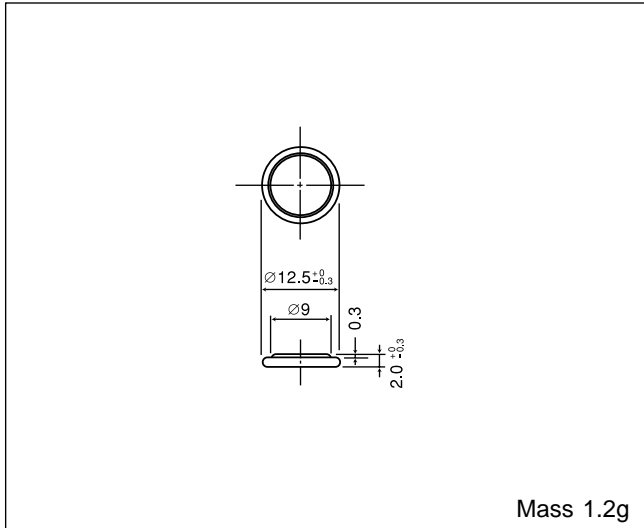

## ■ Specification

<b>Nominal voltage(V)</b>	3
<b>Nominal capacity(mAh)</b>	35
<b>Continuous drain(mA)</b>	0.1
<b>Operating temperature(°C)</b>	-30 ~ +60

## ■ Temperature Characteristics

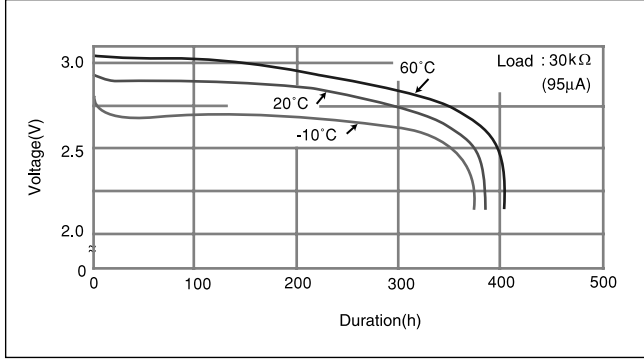

## ■ Operating voltage vs. load resistance(voltage at 50% discharge depth)

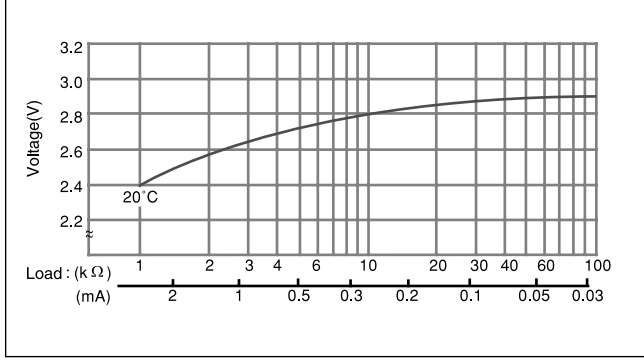

## ■ Capacity vs. load resistance

